

USER MANUAL

10.0 cu.ft. CHEST FREEZER

ECF10ME2CW

Product may vary. Please refer to the actual product.



CONTENTS

1 Safety Warnings

1.1 Warning	1-2
1.2 Meaning of safety warning symbols	3
1.3 Electricity related warnings	3
1.4 Related warnings for use	4
1.5 Warnings related to placing items	5
1.6 Warnings for energy	5
1.7 Warnings related to disposal	5

2 Proper Use of Freezer

2.1 Names of components	6
2.2 Temperature control	7
2.3 Placement	8
2.4 Start to use	8
2.5 Energy saving tips	8

3 Maintenance of Freezer

3.1 Cleaning	9
3.2 Defrost	9
3.3 Stop using	9

4 Troubleshooting

5 Maintenance of Freezer

DEAR CUSTOMER:

Thank you for buying this freezer. To ensure that you get the best results from your new freezer, please take time to read through the simple instructions in this booklet. Please ensure that the packing material is disposed of in accordance with the current environmental requirements.

When disposing of any freezer equipment please contact your local waste disposal department for advice on safe disposal. This appliance must be only used for its intended purpose.

1 Safety Warnings

1.1 Warning



WARNING: risk of fire / flammable materials

This appliance is intended to be used in household and similar applications such as staff kitchen areas in shops, offices and other working environments, farmhouses and by clients in hotels, motels and other residential type environments, bed and breakfast type environments, catering and similar non-retail applications.

This appliance is not intended for use by persons (including children) with reduced physical, sensory or intellectual capabilities, or lack of experience and knowledge, unless they have been given supervision or instruction concerning use of the appliance by a person responsible for their safety.

Children should be supervised to ensure that they do not play with the appliance.

If the supply cord is damaged, it must be replaced by the manufacturer, its service agent or similarly qualified persons in order to avoid a hazard.

Do not store explosive substances such as aerosol cans with a flammable propellant in this appliance. The appliance must be unplugged after use and before carrying out user maintenance on the appliance.

WARNING : Keep ventilation openings, in the appliance enclosure or in the built-in structure, clear of obstruction.

WARNING : Do not use mechanical devices or other means to accelerate the defrosting process, other than those recommended by the manufacturer.

WARNING : Do not damage the refrigerant circuit.

WARNING : Do not use electrical appliances inside the food storage compartments of the appliance, unless they are of the type recommended by the manufacturer.

WARNING : Properly dispose of the freezer according to local laws and regulations pertaining to flammable gases and refrigerants.

WARNING : When positioning the appliance, ensure the supply cord is not trapped or damaged.

WARNING : Do not locate multiple portable socket-outlets or portable power supplies at the rear of the appliance.

Do not use extension cords or ungrounded (two prong) adapters.

WARNING: Risk of child entrapment. Before you throw away your old refrigerator or freezer:
–Take off the doors.
–Leave the shelves in place so that children may not easily climb inside.

WARNING : To avoid a hazard due to instability of the appliance, it must be fixed in accordance with the instructions.

WARNING : Connect to potable water supply only. (Suitable for ice making machine)



The freezer must be disconnected from the source of electrical supply before attempting the installation of accessory.

Refrigerant and cyclopentane foaming material used for the appliance are flammable. Therefore, when the appliance is scrapped, it should be kept away from any fire source and be recycled by a special recycling company with corresponding qualification other than be disposed by combustion, so as to prevent damage to the environment or any other harm.

For doors or lids fitted with locks and keys, keep the keys out of the reach of children and not in the vicinity of the refrigerating appliance, in order to prevent children from being locked inside .

To prevent a child from being entrapped, keep out of reach of children and not in the vicinity of the freezer. (Suitable for products with locks).

1.2 Meaning of safety warning symbols

	The symbols indicate prohibited matters, and those behaviors are forbidden. Non-compliance with the instructions may result in product damages or endanger the personal safety of users.
	The symbols indicate matters that must be followed, and those behaviors must be strictly executed in line with the operation requirements. Non-compliance with the instructions may result in product damages or endanger the personal safety of users.
	The symbols indicate matters to pay attention to, and these behaviors must be especially noted. Precautions are needed; otherwise minor or moderate injuries or damages of the product will be caused.

This manual contains a lot of important safety information which should be observed by the users.

1.3 Electricity related warnings

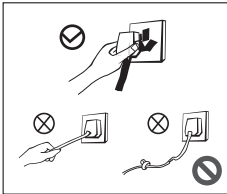

- Do not pull the power cord when pulling the power plug out of the outlet. Firmly grasp the plug and pull it directly out from the outlet.
- Do not damage the power cord under any condition to ensure safety use. Do not use when the power cord is damaged or the plug is worn.
- Worn or damaged power cord should be replaced in manufacturer-authorized maintenance stations.

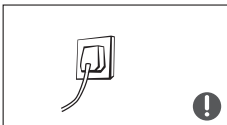

- The power plug should be firmly contacted with the socket or else fires might be caused. Ensure that the grounding electrode of the power socket is equipped with a reliable grounding line.



- Turn the valve off if there is leaking gas and then open the doors and windows in case of leakage of gas and other flammable gases.
- Do not unplug the freezer and other electrical appliances considering that spark may cause a fire.

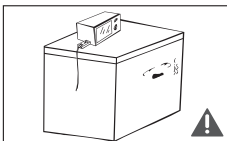

- To ensure safety, it is not recommended to place regulators, rice cookers, microwave ovens and other appliances on the top of the freezer. Those recommended by the manufacturer are not included. Do not use electrical appliances in the food pan.

1.4 Related warnings for use

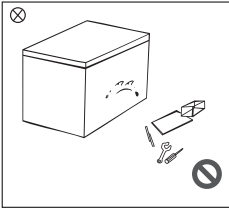

- Do not arbitrarily disassemble or reconstruct the freezer, nor damage the refrigerant circuit. Maintenance of the appliance must be conducted by a specialist.
- Damaged power cord must be replaced by the manufacturer, its maintenance department or related professionals in order to avoid danger.

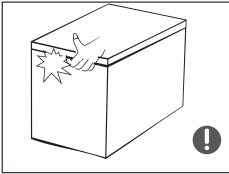

- The gaps between freezer doors and between doors and freezer body are small. Do not put your hand in these areas to prevent from squeezing the finger. Be considerate when open the freezer door to avoid falling articles.
- Do not pick up food or containers with wet hands in the freezing chamber when the freezer is running; especially metal containers in order to avoid frostbite.

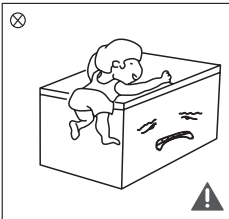

- Do not allow children to enter or climb into the freezer to prevent from being sealed in the freezer or children being injured by the falling freezer.
- Do not spray or wash the freezer. Do not put the freezer in moist places easy to be splashed with water to not affect the electrical insulation properties of the freezer.

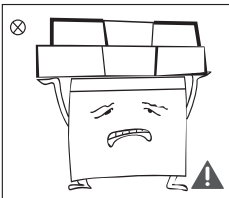

- Do not place heavy objects on the top of the freezer considering that objects may fall when open the door. Accidental injuries might be caused.
- Pull the plug out in case of power failure or cleaning. Do not connect the freezer to a power supply within five minutes to prevent damages to the compressor due to successive starts.

1.5 Warnings related to placing items

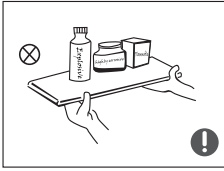

- Do not put flammable, explosive, volatile and highly corrosive items in the freezer to prevent damages to the product or fire accidents.
- Do not place flammable items near the freezer to avoid fires.

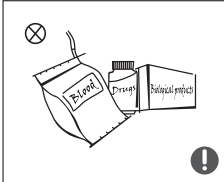

- This product is a household freezer and should be only suitable for the storage of foods. According to national standards, household freezers should not be used for other purposes, such as storage of blood, drugs or biological products.

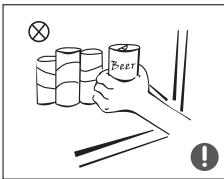

- Do not place items such as bottles or sealed containers of fluid such as bottled beers and beverages in the freezer to prevent bursts and other losses.

1.6 Warnings for energy

- 1) The freezer might not operate consistently when sited for an extended period of time below the cold end of the range of temperatures for which the freezer appliance is designed.
- 2) Effervescent drinks should not be stored in freezer compartments or cabinets, in low-temperature compartments or cabinets, and that some products such as water should not be consumed too cold.
- 3) Do not exceed the storage time recommended by the food manufacturers for any kind of food and particularly for commercially quick-frozen food in food-freezer and frozen-food storage compartments or cabinets.
- 4) Take the necessary precautions to prevent undue rise in the temperature of the frozen food while defrosting the refrigerating appliance, such as wrapping the frozen food in several layers of newspaper.
- 5) A rise in temperature of the frozen food during manual defrosting, maintenance or cleaning could shorten the storage life.

1.7 Warnings related to disposal



The freezer's refrigerant and cyclopentane foam materials are combustible materials and discarded freezers should be isolated from fire sources and can not be burned. Transfer the freezer to qualified professional recycling companies for processing to avoid damages to the environment or other hazards.



Remove the door of the freezer and shelves, which should be properly placed to avoid accidents of children entering and playing in the freezer.



Correct Disposal of this product:

This marking indicates that this product should not be disposed with other household wastes. To prevent possible harm to the environment or human health from uncontrolled waste disposal, recycle it responsibly to promote the sustainable reuse of material resources. To return your used device, use the return and collection systems or contact the retailer where the product was purchased. They can take this product for environmental safe recycling.

2 Proper Use of Freezer

2.1 Names of components

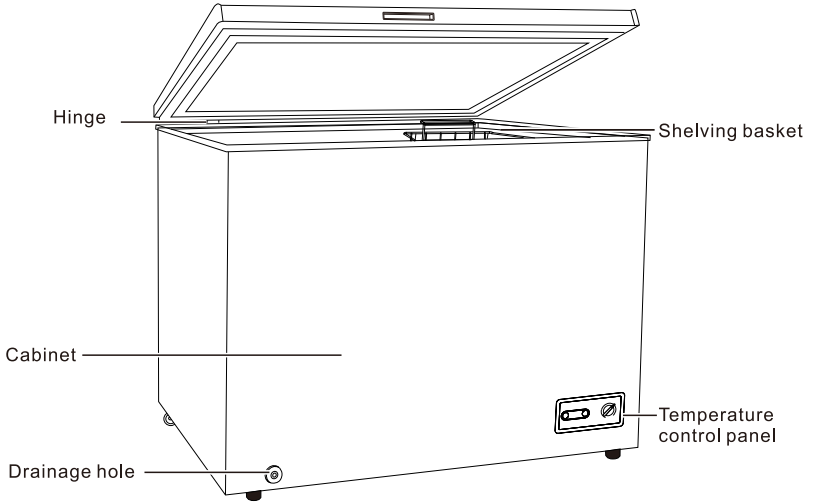

(The picture above is only for reference. The actual configuration will depend on the physical product or statement by the distributor)

2.2 Temperature Control

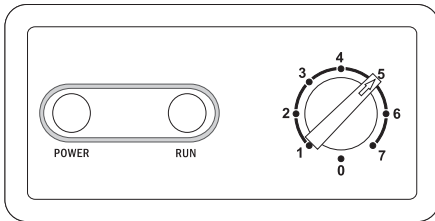

Setting the Temperature Control

Using this setting allows the appliance to store frozen foods and ice. The internal temperature will be between $-14 \sim -24^{\circ}\text{C}$ ($6.8 \sim -11.2^{\circ}\text{F}$). Do not place liquid items in sealed bottles or containers into the appliance when it is being used as a freezer to avoid damage caused by expansion and cracking of the container. While set as a Freezer this model will perform in ambient temperatures between $0^{\circ}\text{F} \sim 110^{\circ}\text{F}$ ($-17^{\circ}\text{C} \sim 43^{\circ}\text{C}$).

Important:

- 1 indicates the warmest setting.
- 7 indicates the coldest setting.
- Setting the thermostat dial in the middle of the 1-7 range should be sufficient for regular home use.
- Setting the thermostat to 7 in the "FREEZING" range will cause the compressor to run continuously and will make the interior very cold. It is not recommended to run the appliance at this setting for long periods of time.
- The temperature inside the appliance can vary based on ambient room temperature, the frequency that the lid is opened and the amount of fresh food that has recently been added to the appliance.
- Do not overload the appliance as this can affect performance.
- Do not freeze large quantities of fresh food at the same time.

(The picture above is only for reference. The actual configuration will depend on the physical product or statement by the distributor)

2.3 Placement

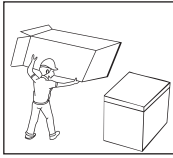

- Before using the freezer, remove all packaging materials including bottom cushions, foam pads, and tapes inside the freezer. Tear off the protective film on the door and the freezer body.

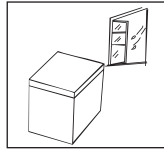

- The freezer should be placed in a well-ventilated indoor place, and the ground should be flat and sturdy.

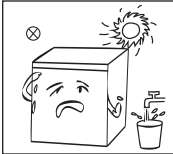

- Keep away from heat and avoid direct sunlight. Do not place the freezer in moist or watery places to prevent rust or reduction of insulating effect.

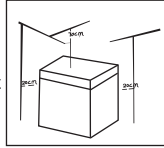

- The top space of the freezer should be greater than 70cm, and the distances from both sides and backside should be more than 20cm to facilitate heat dissipation.

2.4 Start to use

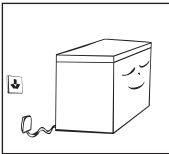

- The freezer should sit for half an hour before connecting power when it is started.
- The freezer should run 2 to 3 hours before loading fresh or frozen food. The freezer should run for more than 4 hours in summer in advance considering that the ambient temperature is high.

2.5 Energy saving tips

- The appliance should be located in the coolest area of the room, away from heat producing appliances or heating ducts, and out of the direct sunlight.
- Let hot foods cool to room temperature before placing in the appliance. Overloading the appliance forces the compressor to run longer. Food that freezes too slowly may lose quality, or spoil.
- Be sure to wrap food properly, and wipe containers dry before placing them in the appliance. This cuts down on frost build-up inside the appliance.
- Appliance storage bin should not be lined with aluminum foil, wax paper, or paper toweling. Liners interfere with cold air circulation, making the appliance less efficient.
- Organize and label food to reduce door openings and extended searches. Remove as many items as needed at one time, and close the door as soon as possible.

3 Maintenance of Freezer

3.1 Cleaning

- Dust behind the freezer and on the ground should be timely cleaned to improve the cooling effect and energy saving.
- Check the door gasket regularly to make sure there is no debris. Clean the door gasket with a soft cloth dampened with soapy water or diluted detergent.
- The interior of the freezer should be cleaned regularly to avoid odor.
- Turn off the power before cleaning, remove all food, basket, container, etc.
- Use a soft cloth or sponge, two tablespoons of baking soda and a quart of warm water to clean the inside of the freezer. Rinse with water and wipe clean. After cleaning, open the door and let it dry naturally before turning on the power.
- For areas that are difficult to clean in the freezer (such as gaps or corners), it is recommended to wipe them regularly with a soft rag, soft brush, etc. and when necessary, combine with some auxiliary tools (such as thin sticks) to ensure no contaminants or bacteria accumulated in these areas.
- Do not use soap, detergent, scrub powder, spray cleaner, etc., as these may cause odors in the interior of the freezer or contaminate food.
- Clean the baskets with a soft cloth dampened with soapy water or diluted detergent. Dry with a soft cloth or dry naturally.
- Wipe the outer surface of the freezer with a soft cloth dampened with soapy water, detergent, etc., and then wipe dry.
- Do not use hard brushes, clean steel balls, wire brushes, abrasives (such as toothpastes), organic solvents (such as alcohol, acetone, banana oil, etc.), boiling water, acid or alkaline items, which may damage the freezer surface and interior. Boiling water and organic solvents such as benzene may deform or damage plastic parts.
- Do not rinse directly with water or other liquids during cleaning to avoid short circuits or affect electrical insulation after immersion.



 Unplug the freezer for defrost and cleaning.

3.2 Defrost

- Freezer should be manually defrosted. Unplug the freezer, open the freezer door, remove food and the shelving basket before defrosting. Open the outflow hole and drainage hole and place a water container at the outflow hole. Indoor frost will naturally melt. Wipe the defrost water with a dry, soft cloth. When the frost softens, an ice scraper might be used to accelerate de-icing process.
- Remove the food and put in a cool place when defrosting before removing accessories.

 Other mechanical devices or other means should not be used to accelerate except those recommended by the manufacturer. Do not damage the refrigerant circuit.

3.3 Stop using

- Power failure: In case of a power failure, food can be preserved for hours, even in summer. It is recommended to reduce the frequency of opening door and do not put fresh foods into the freezer.
- Long-time nonuse: Unplug the freezer if left unused for a long time for cleaning. Keep the door open to avoid the bad odor.
- Moving: Do not vibrate or turn the freezer upside-down. The carrying angle cannot be greater than 45°. Do not hold the door and hinge when moving this unit.

 Continuous operation is recommended when the freezer is started. Do not stop the freezer under normal circumstances so as not to affect the freezer's service life.

4 Troubleshooting

The following simple issues can be handled by the user. Please call the after-sale service department if the issues are not settled.

Failed operation	Whether the freezer is plugged and connected to power. Low voltage. Whether temperature control knob is in the work area. Failure power or tripping circuit.
Odor	Odorous food should be tightly wrapped. Whether food is rotten. Whether the interior should be cleaned.
Long-term operation of compressor	It is normal that the freezer operates for longer time in summer when the ambient temperature is higher. Do not put too much food in the freezer at one time. Do not put in food until it is cooled Frequent opening of freezer door. Thick frost layer (defrost is needed).
Illuminating light does not shine	Whether the freezer is connected to power. Whether the light is damaged.
The freezer door can not be properly closed	The freezer door is stuck by food packages. Too much food. Unbalanced freezer.
Loud noises	Whether the floor is flat, whether the placement of freezer is stable. Whether the freezer accessories are properly placed.
Transient difficulty in door opening	After refrigeration, there will be pressure difference between the inside and outside of the freezer to result in transient difficulty in door opening. This is a normal physical phenomenon.
Freezer enclosure heat Condensation	The freezer enclosure may emit heat during operation; especially in summer. This is caused by the radiation of the condenser, which is normal. Condensation: condensation phenomenon will be detected on the exterior surface and door seals of the freezer when the ambient humidity is large. This is a normal phenomenon, and the condensation can be wiped away with a dry towel.
Airflow sound Buzz Clatter	Refrigerants circulating in the refrigerant lines will produce eruption of sound and grunts, which is normal and does not affect the cooling effect. A buzz will generate by running the compressor; especially when starting up or shutting down. The solenoid valve or electric switch valve will clatter which is a normal phenomenon and does not affect the operation.

Element Appliance Limited Warranty

(the “Products” or “Product” when referencing a singular product herein)

This Product (including any accessories included in the original packaging) as supplied and distributed in new condition, is warranted by Element Appliance Company, LLC (“Element”) to the original customer who purchases the Product from an authorized Element retailer (the “Original Customer” or “you”) against defects in material and workmanship under proper use, maintenance, and care according to the owner’s manual, warnings, and instructions accompanying the Product (“Warranty”) as follows:

* **PLEASE NOTE** – Proof of purchase evidencing the date of purchase by the Original Purchaser from an authorized Element retailer (“Valid Proof of Purchase”) is **required** for all Warranty service. The express Warranty set forth herein is subject to all terms and conditions set forth below.

1. WARRANTY SERVICE:

A. ONE-YEAR WARRANTY: Except as provided in subpart 1.B below, for a period of **one (1) year** from the date of purchase by the Original Customer (the “Warranty Period”), if the parts or components covered by this Warranty are determined by Element or Element’s authorized service provider to be defective in material or workmanship, Element will, at its sole and absolute discretion and option: (i) repair the defective part or component at no charge to the Original Customer, (ii) replace the defective Product with a new Product of similar or better quality, at no charge to the Original Customer, or (iii) refund the documented purchase price paid by the Original Customer (excluding tax) to the Original Customer upon return of the defective Product as directed by Element. After the Warranty Period expires, the Original Customer must pay for all parts, components, shipping and handling, labor, and replacement costs associated with the Product or any part or component thereof, regardless of any defects in the Product or any part or component thereof.

B. LIMITED EXTENDED WARRANTY THROUGH PRODUCT REGISTRATION: If and only if the Original Customer registers the Product at www.elementelectronics.com within **ninety (90)** days of the date of purchase by the Original Customer, then the Warranty Period discussed in subpart 1.A. above shall be extended an additional one (1) year to a new Warranty Period equaling **two (2) years** from the date of purchase by the Original Customer. If the Product is not registered as provided for in this subpart 1.B, then the standard one-year Warranty Period set forth in subpart 1.A shall apply.

C. TIMING AND PROCEDURE: Before Warranty service can commence, the Original Customer must contact either (i) the retailer from whom the Original Customer purchased the Product, or (ii) Element directly, in either case for problem determination and service procedures. Valid Proof of Purchase evidencing that the Product is within the Warranty Period **MUST** be presented by Original Customer in order to obtain the requested Warranty service. Please have your model and serial number available, along with your date of purchase of the Product. To remain eligible for Warranty service, Original Customer may not return the Product or any part or component thereof to the retailer or Element without Element’s prior written consent.

2. EXCLUSIONS AND LIMITATIONS TO WARRANTY SERVICE

The Warranty covers manufacturing defects in materials and workmanship of the Product encountered in the normal, non-commercial use of the Product, and **does not cover** (a) damages or malfunctions resulting from improper or unreasonable use or maintenance, abuse, negligence, failure to follow instructions contained in any written materials that accompany the Product, deterioration by reason of excess moisture, corrosive atmosphere, lightning, power surges, connections to improper voltage supply, unauthorized alteration, or other external causes such as extremes in temperature or humidity, modifications, scratches or discoloration; (b) improper or incorrectly performed repairs by service providers not authorized by Element; (c) transportation, shipping, delivery, pickup, insurance, installation, or set-



up costs; (d) ordinary wear and tear, cosmetic damage, or damage due to acts of nature, including but not limited to, water, floods, wind, storm, tornado, earthquake, or fire, or due to damage caused by extraordinary impact events, such as dropping, crushing, demolition or other extraordinary damage; (e) commercial use of the Product, or use of the Product for anything other than single-family household or residential use; or (f) modification of the Product or any part of the Product.

This Warranty is made to the Original Customer only and does not cover Products sold AS IS or WITH ALL FAULTS. The Warranty is invalid if the factory-applied serial number has been altered or removed from the Product. This Warranty is valid only in the United States, and only applies to Product if it was purchased and serviced in the United States. The addition of equipment or features to the Product that are not manufactured or recommended by Element could affect the intended function of the Product, and therefore may void the Warranty. Furthermore, the exposure of the Product to chemicals, heat, cold, humidity, or other elements can affect the Product components, and therefore, the Warranty does not cover discoloration, fading, cosmetic changes, rust, or any damages or failure related to any such items. The Warranty is contingent upon the proper use, maintenance, and care of the Product. The Warranty may be void if the Product has been used in a manner contradictory to, or in violation of, the terms of the user's manual, warnings, or instructions accompanying the Product.

THIS WARRANTY IS MADE IN LIEU OF AND SUPERSEDES ALL OTHER WARRANTIES OR CONDITIONS OF MERCHANTABILITY OR FITNESS FOR A PARTICULAR PURPOSE OR GENERAL USE, WHETHER EXPRESS, IMPLIED, COLLATERAL, STATUTORY, OR PROVIDED BY COMMON LAW, THE UNIFORM COMMERCIAL CODE, OR OTHERWISE. ELEMENT FURTHER DISCLAIMS ALL WARRANTIES AFTER THE END OF THE WARRANTY TERM DEFINED ABOVE. NO OTHER EXPRESS WARRANTY OR GUARANTY GIVEN BY ANY OTHER PERSON, FIRM, OR ENTITY WITH RESPECT TO THE PRODUCT SHALL BE BINDING ON ELEMENT. REPAIR, REPLACEMENT, OR REFUND OF THE ORIGINAL PURCHASE PRICE, AT ELEMENT'S SOLE DISCRETION, ARE THE EXCLUSIVE REMEDIES OF THE CUSTOMER.

ELEMENT SHALL NOT BE LIABLE FOR ANY INCIDENTAL OR CONSEQUENTIAL DAMAGES CAUSED BY THE USE, MISUSE, OR INABILITY TO USE THE PRODUCT. THESE INCLUDE, BUT ARE NOT LIMITED TO, ANY DAMAGES IN THE FORM OF LOST PROFITS, LOSS OF USE, LEGAL FEES, ECONOMIC LOSS, PERSONAL INJURIES, OR ANY OTHER DAMAGES CAUSED BY CIRCUMSTANCES BEYOND THE CONTROL OF ELEMENT. NOTWITHSTANDING THE FOREGOING, ELEMENT'S AGGREGATE LIABILITY TO ANY CUSTOMER SHALL NOT EXCEED THE ORIGINAL PURCHASE PRICE OF THE PRODUCT. THIS WARRANTY SHALL NOT EXTEND TO ANYONE OTHER THAN THE ORIGINAL CUSTOMER WHO PURCHASED THE PRODUCT, AND IS NOT TRANSFERABLE. NO PERSON IS AUTHORIZED TO ALTER, EXTEND, OR WAIVE THIS WARRANTY OR ANY OF ITS TERMS OR CONDITIONS.

Some states do not allow the exclusion or limitation of incidental or consequential damages, or allow limitations on warranties, so the above limitations or exclusions may not apply to you. This Warranty gives you specific rights, and you may have other rights, which vary from state to state. The exclusions and limitations to the Warranty apply to the maximum extent permitted by law and unless restricted or prohibited by law. Where any term of this Warranty is prohibited by applicable law, it shall be null and void, but the remainder of this Warranty shall remain in effect.

PLEASE DIRECT ALL CORRESPONDENCE TO:

Element Appliance Company, LLC
customerservice@elementelectronics.com
(888) 842-3577
<https://elementelectronics.com>





Element, the Element Logo, and Bring it home are trademarks of Element Brand Holding, LLC. All other trademarks are the property of their respective owner, who has not sponsored, endorsed, or approved this product.
©2023 Element Appliance Company, LLC. All rights reserved.

Distributed by Element Appliance Company, LLC
Augusta, GA 30909

For service, support and warranty information:
Call 888.842.3577, email us at customerservice@elementelectronics.com or visit www.elementelectronics.com