



ESBAE20
2.0 Sound Bar

USER **MANUAL**



WHAT'S INCLUDED



Your new sound bar!

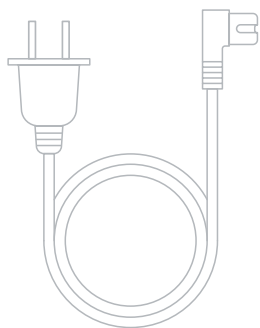

Power cord



HDMI cable



Audio cable



Remote

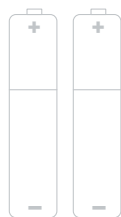

**2 AAA
remote batteries**

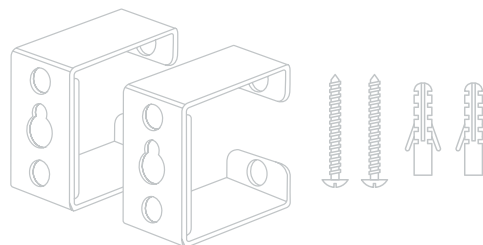

**Wall
mounting kit**

FOR YOUR ATTENTION

- Please read through this manual before making connections and operating your new sound bar. Retain this manual for future reference.
- Do not open the cabinet of this unit; there are no user-serviceable parts inside. Refer servicing to qualified personnel only.
- Switch off the unit when not in use. Switch off the unit and disconnect it from the AC power supply when not in use for an extended period of time.
- Do not install the unit in a place exposed to heating sources or direct sunlight.
- Do not install the unit in a place exposed to moisture or rain.
- The sound bar should not be exposed to dripping or splashing, and objects filled with liquids should not be placed on top of the unit.
- Install the unit on a horizontal, flat and firm surface with good ventilation. Never block the vents which will cause malfunction, resulting from overheating.
- Use a soft and clean rag to clean the outside of the unit. Never clean it with chemicals or detergent.
- This book is only a guide for user's operation, not a criterion for configuration.
- Only use attachments/accessories specified by the manufacturer.
- Where the main plug is used as the disconnect device, the disconnect device shall remain readily operable.

⚠ WARNING: The batteries shall not be exposed to excessive heat such as sunshine, fire or the like.

⚠ CAUTION: Danger of explosion if battery is incorrectly replaced. Replace only with the same or equivalent type.



The lightning flash is intended to alert the user to the presence of dangerous voltage within the product's enclosure, and touching the internal components may result in a risk of electric shock to persons.



The exclamation mark is intended to alert the user to the presence of important operating instructions.



To reduce the risk of electric shock or fire, do not open the cover. Refer servicing to qualified service personnel.

MOUNTING YOUR SOUND BAR ON A WALL

In order to prevent injuries, the sound bar device must be fastened securely to the wall in accordance with the below installation instructions.

SUGGESTED WALL MOUNTING HEIGHT: ≤ 59in

1. Drill two parallel holes into the wall (about 0.22" - 0.24" (1/4") in diameter). The distance between the holes should be 30.3"
2. If needed, firmly fix 1 dowel into each hole in the wall, insert screws leaving 0.12" (1/8") clearance from wall.

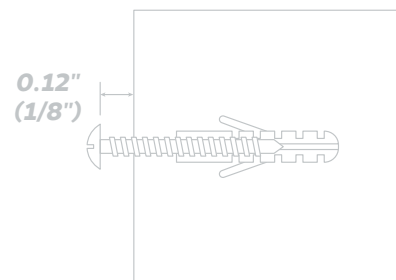
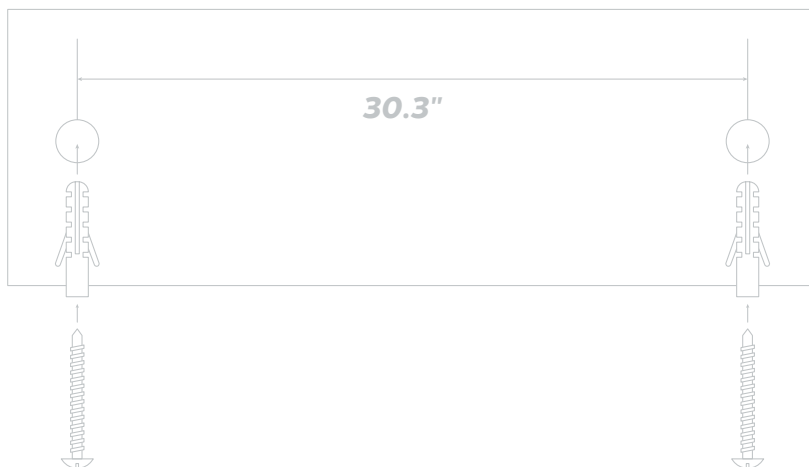

Leave 0.12" (1/8") distance between the screw heads and the wall.

MOUNTING YOUR SOUND BAR ON A WALL

(continued)

3. Unscrew the four screws from the back of the Sound Bar, place brackets on each set of holes and replace screws to hold brackets firmly in place

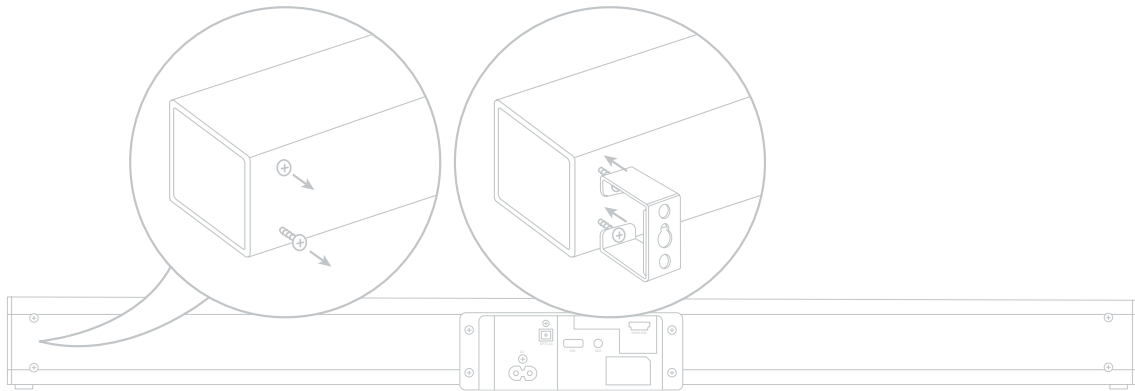

4. Lift unit onto wall, aligning the wall screws into the holes in the brackets and slot into place

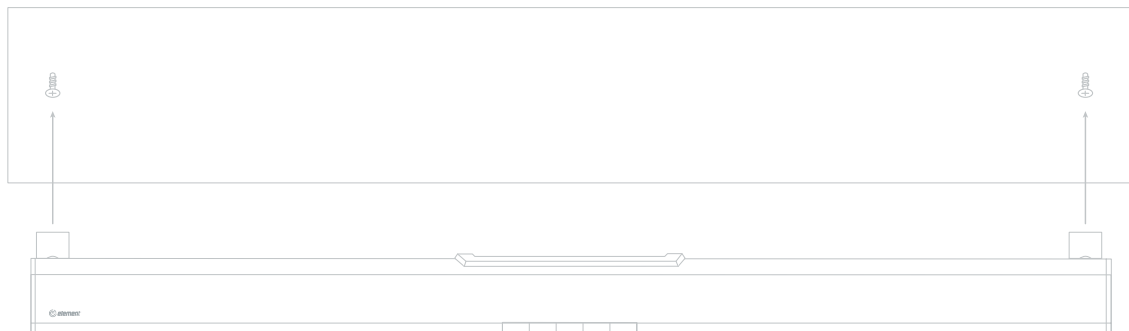

SOUND BAR PANELS

Front

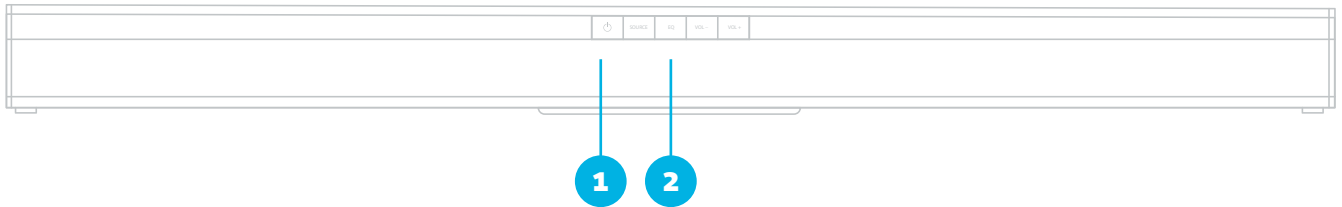

1 Remote Control Sensor

2 LED Display

3 Power Turn sound bar on or off

4 Source Select input audio source

5 EQ Select the sound effect

6 Volume Down Turn down audio volume

7 Volume Up Turn up audio volume

Front Controls

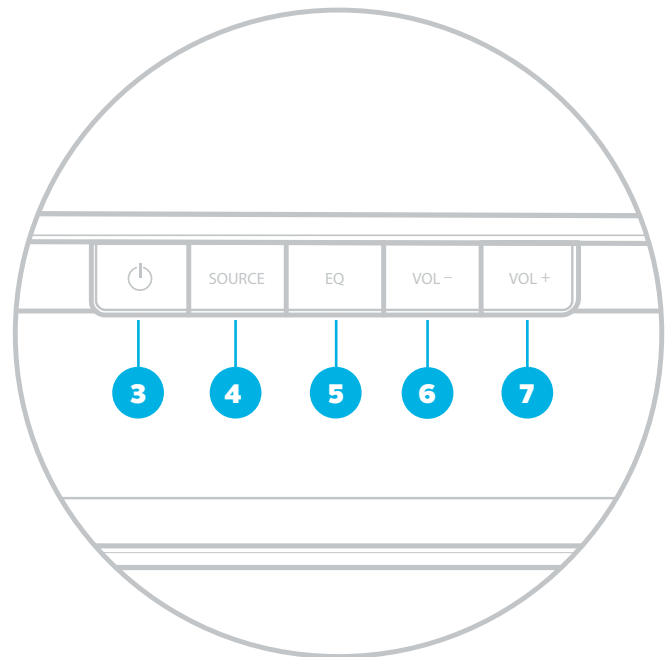

SOUND BAR PANELS

(continued)

Back



Back Connections

8 WALL BRACKET SCREWS

9 AC IN

10 OPTICAL

11 USB

12 AUX IN

13 HDMI (ARC)

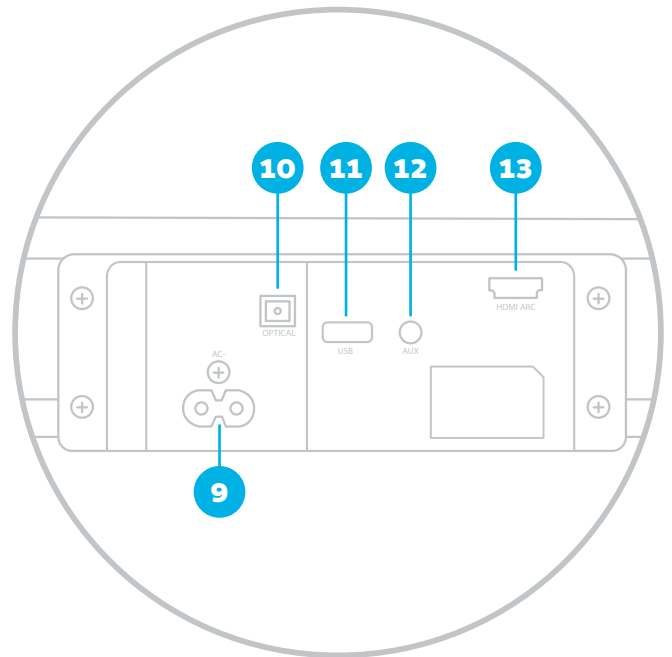

CONNECT TO YOUR TV

There are 4 ways to connect your sound bar to the TV:

- 1 **HDMI (ARC)** Best Quality *(cable included)*
- 2 **Optical** Better Quality *(cable not included)*
- 3 **AUX** Good Quality *(cable not included)*
- 4 **USB** Good Quality *(cable not included)*

HDMI ARC (AUDIO RETURN CHANNEL)

ARC is an audio return channel function for digital audio which will give you the best sound quality. Use the supplied ARC cable to connect to the HDMI ARC input of your sound bar and the HDMI ARC output on your TV or other external device.

Press  button on the remote control to select HDMI ARC mode. The display will show **ARC** which means that **HDMI ARC** mode is selected.

Note: The external device audio output must be set to HDMI.

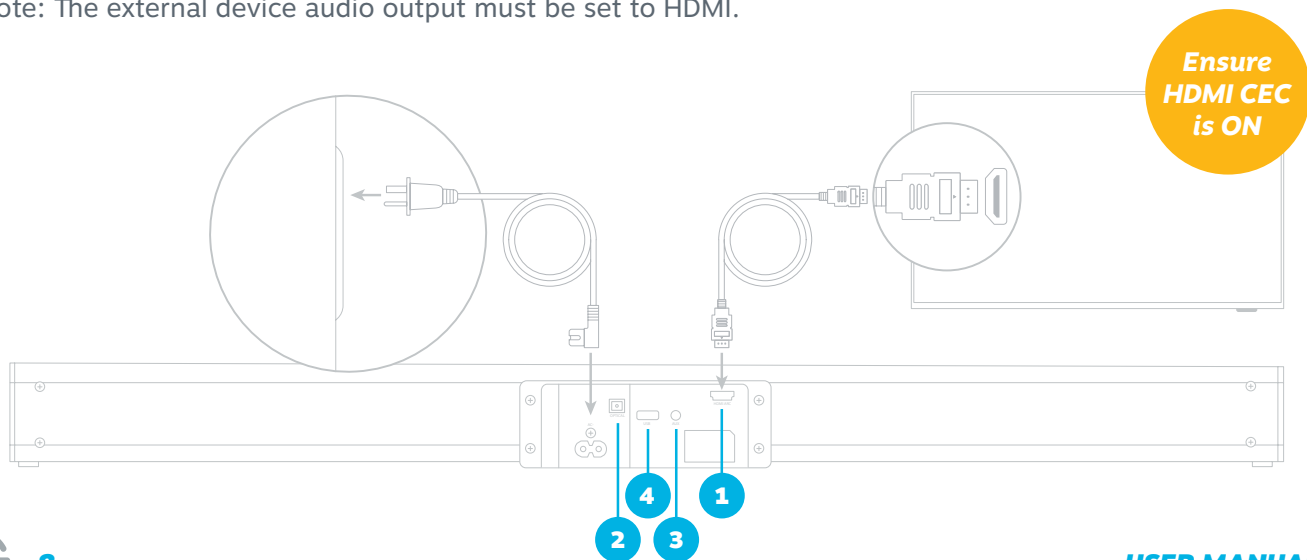

CONNECTIONS

Optical

Connect your sound bar to your TV or other external devices such as a CD, VCR, DVD player, etc., by connecting an optical input cable (cable not included) to your sound bar and the optical output of your external device.

Press  button on the remote control to select optical input mode. The display will show **OPT** which means that **OPTICAL** mode is selected.

Note: The external device audio output must be set to PCM.



AUX

This sound bar has an extra group of audio input terminals.



Connect your sound bar to your TV or other external devices such as a CD, VCR, DVD player, etc. by connecting an AUX input cable (cable not included) to your sound bar and the AUX output of your external device.

Press  button on the remote control to select AUX input mode. The display will show **AUX** which means that **AUX** mode is selected.



USB

Connect a USB drive to your sound bar to play digital audio files.

Press  button on the remote control to select USB mode and play should start automatically. If play does not start automatically, press  . To skip to the previous/next track, press  on the remote control. The display will show **USB** which means that **USB** mode is selected.



CONNECTIONS

(continued)

Bluetooth®

Press the **POWER** button on the remote control to power on the sound bar, then press **Bluetooth** button on the remote control to switch to Bluetooth mode. The display will show **BT** which means that **BLUETOOTH** mode is selected.

If after several seconds the display does not read **BT**, the sound bar is still searching for a signal and you can follow these steps:

Pairing a device or connecting a paired device:

1. Press and hold the play/pause button on the remote control. Use your smart device to search for the Bluetooth signal of the sound bar.
2. Select ESBAE20 on your list of Bluetooth connections.
3. The sound bar will then sync to play from your device.
When the display reads **BT** and a beep is heard, it means you are connected successfully.

Disconnecting a device:

Press and hold the play/pause button on the remote control. When it successfully disconnects the screen will show **NO Bluetooth**.

TIP: Bluetooth connection range is 30 feet.

In Bluetooth mode, [PLAY/PAUSE], [NEXT], [PREVIOUS], [VOLUME+/-] etc. are also active.

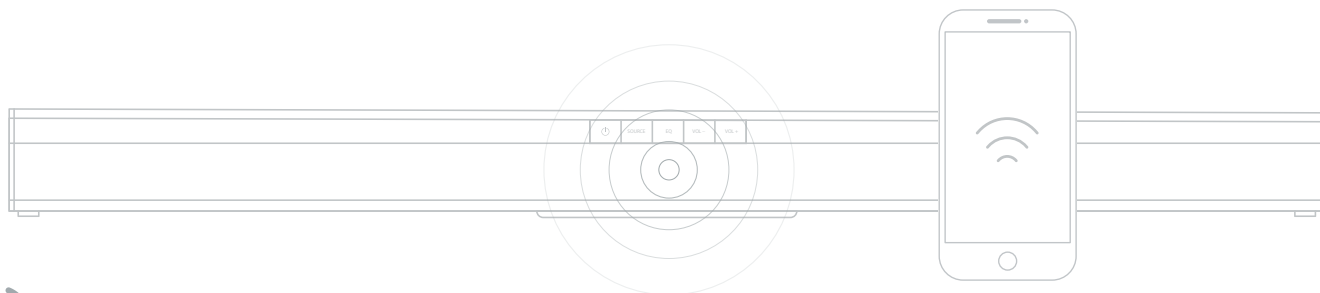

REMOTE CONTROL

Remote control operation

Insert the batteries into the remote control. Point the remote control at the remote sensor on the front panel. The remote control works within a distance of about 6 meters from the sensor and within an angle of about 30 degrees from the left and right side.



Battery installation

Remove the battery compartment cover on the back of the remote.

Load two AAA/1.5V batteries into the battery compartment making sure that the battery has been inserted with the correct polarities matching the symbols +, - as indicated inside the battery compartment.

Replace the cover.

NOTE:

- Remove the battery when you do not intend to use the remote control for a long time.
- Weak battery can leak and severely damage the remote control.
- The battery must not be exposed to excessive heat source, such as sunshine, fire or anything that would dramatically raise the temperature of the battery.
- Be environmentally friendly and dispose of batteries according to local government regulations.



REMOTE CONTROL

(continued)

- 1 Power
- 2 Source
- 3 Volume Up/Down
- 4 News/Music/Movie
- 5 Mute
- 6 Previous/Next
- 7 Play/Pause
- 8 Bluetooth

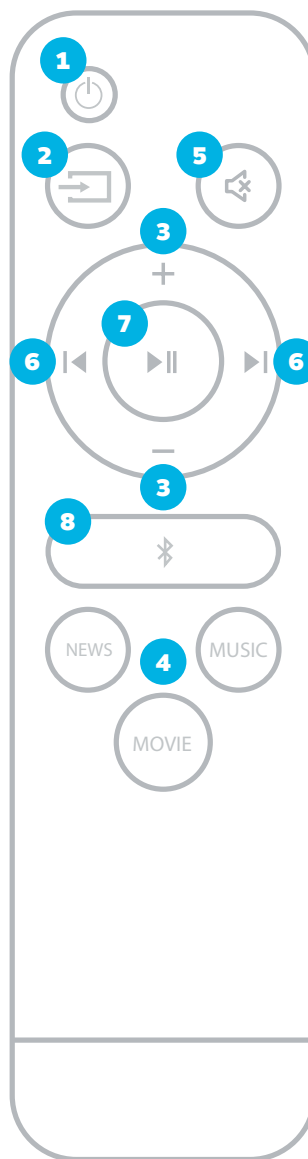

BASIC PLAYBACK



Press to switch on the unit. Press it again to put the unit in standby mode.



Press to switch to Bluetooth mode, hold down button for 3 sec to disconnect Bluetooth mode.



Press for AUX / HDMI ARC / OPTICAL / USB mode



Press to enter MOVIE mode.



Press to enter NEWS mode.



Press to enter MUSIC mode.

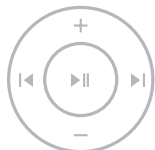

- ▶|| Press to temporarily pause a playback. Press it again to resume the playback.
- ◀ Press to return to the previous track.
- ▶ Press to skip to the next track.
- + Press [VOLUME +] to turn up the volume.
- Press [VOLUME -] to turn down the volume.



Press to temporarily switch off the sound. Press it again to switch it on.



TROUBLESHOOTING

Use the chart below to troubleshoot any issues you may be having. If you do not see your issue listed below, or the troubleshooting guide does not solve your issue, please contact Element customer support.

SYMPTOM	CAUSE	REMEDY
No Power	<ul style="list-style-type: none">· AC power cord is not connected to a power supply securely	<ul style="list-style-type: none">· Check that the AC power cord is connected securely
There is no sound or the sound is distorted	<ul style="list-style-type: none">· The audio cables aren't connected securely· The volume is set to the minimum level· The sound is switched off	<ul style="list-style-type: none">· Connect the audio cables securely.· Turn up the volume· Press [MUTE] on the remote control to switch on the sound· Press [PLAY/PAUSE]
The remote control does not function	<ul style="list-style-type: none">· There is no battery in the remote control· The battery is out of charge· The remote control isn't pointed to the remote sensor· The remote control is out of its operating area· The unit is shut down	<ul style="list-style-type: none">· Install two AAA/1.5V batteries in it· Replace the battery with new one· Make sure that the remote control is pointed to the remote control sensor· Make sure the remote control is within the operating area· Switch off the unit and disconnect it from the AC outlet, then power on the unit again



SOUND BAR SPECIFICATIONS

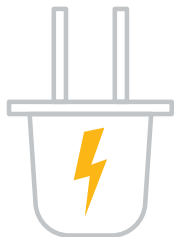

SOUND BAR POWER SUPPLY

AC ~100-240V, 50/60Hz

WORKING ENVIRONMENT



RELATIVE HUMIDITY

5% ~ 90%



TEMPERATURE

14°F - 95°F

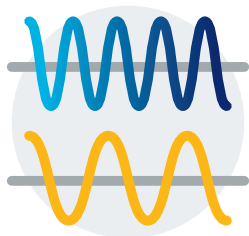

FREQUENCY RESPONSE

40Hz~200Hz



SOUNDBAR MAX POWER OUTPUT

30W X 2



REFERENCES

Element TV Company, LP. bears no responsibility for data and/or information that is compromised during a wireless transmission.

Frequency band

- This system uses the 2.4 GHz frequency band.

Certification

- This system conforms to the frequency restrictions and has received certification based on frequency laws. Thus, a wireless permit is not Necessary.
- The actions below are punishable by law in some countries:
 - Taking apart or modifying the unit.
 - Removing specification indications.

Restrictions of use

- Wireless transmission and/or usage with all Bluetooth equipped devices is not guaranteed.
- All devices must conform to standards set by the Bluetooth SIG, Inc.
- Depending on the specifications and settings of a device, it can fail to connect or some operations can be different.
- This system supports Bluetooth security features. But depending on the operating environment and/or settings, this security is possibly not sufficient. Transmit data wirelessly to this system with caution.
- This system cannot transmit data to a Bluetooth device.

Range of use

- Use this device at a maximum range of 26.2 ft.
- The range can decrease depending on the environment, obstacles or interference.

Interference from other devices

- This system may not function properly and troubles such as noise and sound jumps may arise due to radio wave interference if this unit is located too close to other Bluetooth devices or the devices that use the 2.4 GHz band.
- This system may not function properly if radio waves from a nearby broadcasting station, etc. is too strong.

Intended usage

- This system is for normal, general use only.
- Do not use this system near equipment or in an environment that is sensitive to radio frequency interference (example: airports, hospitals, laboratories, etc.).



LICENSE



The Bluetooth® word mark and logos are registered trademarks owned by Bluetooth SIG, Inc. and any use of such marks by Zhong Shan City Richsound Electronic Industrial Ltd. (Element's manufacturing partner) is under license. Other trademarks and trade names are those of their respective owners.



The terms HDMI, HDMI High-Definition Multimedia Interface, HDMI Trade dress and the HDMI Logos are trademarks or registered trademarks of HDMI Licensing Administrator, Inc.

FCC STATEMENT

1. This device complies with Part 15 of the FCC Rules. Operation is subject to the following two conditions:
 - (1) This device may not cause harmful interference, and
 - (2) This device must accept any interference received, including interference that may cause undesired operation.
2. Changes or modifications not expressly approved by the party responsible for compliance could void the user's authority to operate the equipment.

NOTE: This equipment has been tested and found to comply with the limits for a Class B digital device, pursuant to Part 15 of the FCC Rules. These limits are designed to provide reasonable protection against harmful interference in a residential installation. This equipment generates uses and can radiate radio frequency energy and, if not installed and used in accordance with the instructions, may cause harmful interference to radio communications. However, there is no guarantee that interference will not occur in a particular installation. If this equipment does cause harmful interference to radio or television reception, which can be determined by turning the equipment off and on, the user is encouraged to try to correct the interference by one or more of the following measures:

- Reorient or relocate the receiving antenna.
- Increase the separation between the equipment and receiver.
- Connect the equipment into an outlet on a circuit different from that to which the receiver is connected.
- Consult the dealer or an experienced radio/TV technician for help.

RADIATION EXPOSURE STATEMENT

This equipment complies with FCC/IC radiation exposure limits set forth for an uncontrolled environment. This equipment should be installed and operated with minimum distance 20cm between the radiator & your body.



LET'S REGISTER YOUR PRODUCT



*It's super easy, just head on over to
elementelectronics.com/register*

BENEFITS OF REGISTERING YOUR PRODUCT:



Support

Get assistance quickly by pre-registering your product.



News & Offers

Take advantage of the latest news and special offers from Element.



Updates

Stay current with important product updates and notifications.



Warranty

Receive a 2-year limited warranty with product registration.*

*1-year manufacturer's limited warranty with purchase, or 2-year limited warranty with product registration within 90 days of purchase. See warranty card for details.



WE'RE HERE TO HELP

Find resources and get help for product setup, connecting devices, technical issues, downloading manuals and more!

We're available 24 hours a day, 7 days a week



elementelectronics.com



1.888.842.3577



customerservice@elementelectronics.com

Element offers environmentally responsible options to recycle your unwanted consumer electronics device. More information can be found by visiting: www.elementelectronics.com/sustainability





Element, the Element Logo, and Bring it home are trademarks of Element Brand Holding, LLC. All other trademarks are the property of the respective owner who has not sponsored, endorsed, or approved this product. ©2024, Element Brand Holding, LLC, All Rights Reserved.